

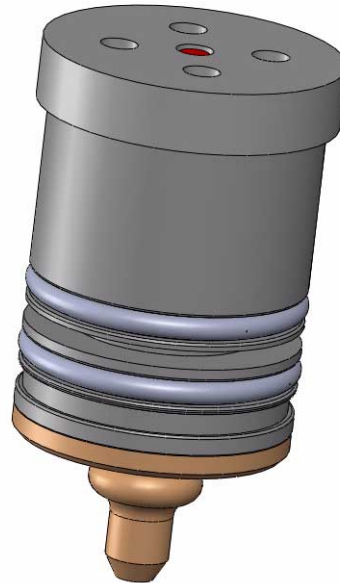

From February 1st, 2017 SAMES Technologies SAS becomes SAMES KREMLIN SAS
A partir du 1/02/17, SAMES Technologies SAS devient SAMES KREMLIN SAS

SAMES  **KREMLIN**



User manual

2K- Microvalves with bellow

FRANCE

SAS SAMES Technologies. 13 Chemin de Malacher 38243 Meylan Cedex
Tel. 33 (0)4 76 41 60 60 - Fax. 33 (0)4 76 41 60 90 - www.sames.com

USA

Exel North America. 45001 5 Mile Road, Plymouth, Michigan, 48 170
Tel. (734) 979-0100 - Fax. (734) 927-0064 - www.sames.com

All communication or reproduction of this document, in any form whatsoever and all use or communication of its contents are forbidden without express written authorisation from SAMES Technologies.

The descriptions and characteristics mentioned in this document are subject to change without prior notice.

© SAMES Technologies 2011



WARNING : SAS Sames Technologies is registered with the Ministry of Labour as a training institution.

Throughout the year, our company offers training courses in the operation and maintenance of your equipment.

A catalogue is available on request. Choose from a wide range of courses to acquire the skills or knowledge that is required to match your production requirements and objectives.

Our training courses can be delivered at your site or in the training centre at our Meylan head office.

Training department:

Tel. 33 (0)4 76 41 60 04

E-mail: formation-client@sames.com

SAS Sames Technologies operating manuals are written in French and translated into English, German, Spanish, Italian and Portuguese.

The French version is deemed the official text and Sames will not be liable for the translations into other languages.

2K- Microvalves with bellow

1. General - - - - -	4
2. Operation - - - - -	4
3. Maintenance- - - - -	4
3.1. <i>Disassembling</i>	5
3.2. <i>Reassembling</i>	5
4. Replacing the microvalve o-rings - - - - -	6
4.1. <i>Disassembly</i>	6
4.2. <i>Reassembly</i>	6
5. Preparing for service - - - - -	6
6. Problems, troubleshooting.- - - - -	7
7. Spare parts- - - - -	8
7.1. <i>Tools</i>	8
7.2. <i>2K-Microvalve with bellow</i>	8

1. General

The 2K microvalves are only used in the 2K atomizer body on the hardener supply circuit and possibly the paint circuit.

2. Operation

When not in use, the valve is closed. The spring (4) actuates the piston (2) permanently secured to the rod which closes the needle (3). The product arriving at (C), cannot flow into (D). The piston rod is sealed from the air by a o-ring (6) located on the bellow. The microvalve body (1) is sealed from the air and the product by seals (5) and (6). An outlet (E) is provided in case of a paint surge.

3. Maintenance

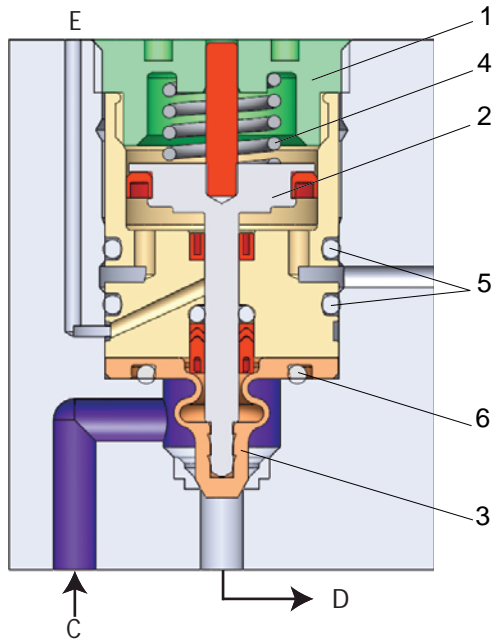

Maintenance is limited to changing the o-rings (5 and 6).

To assist maintenance, you are recommended to coated the outside of the microvalve with vaseline to prevent paint deposits in the event of leakage.

Make a periodic inspection for product leakage, particularly around the detection hole. If there is leakage, carry out the repair immediately as other operating faults may rapidly develop.

Do not soak plastic parts for long periods in aggressive solvents. Do not soak in acids or phenol.

Never soak o-rings in solvents.

O-rings that are deformed or expanded through contact with a solvent-based product must be replaced immediately.



WARNING : Never use sharp instruments for cleaning.



WARNING : After 600,000 operations, check the condition of the bellow, if damage replace the microvalve unit.

3.1. Disassembling

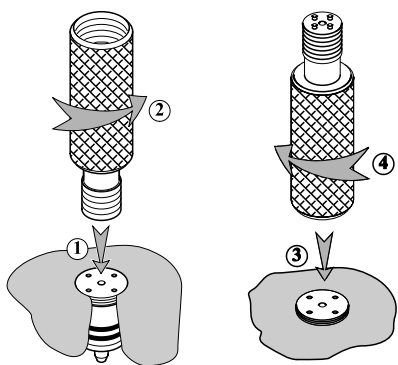

DIES00030

Using the disassembly tool (Ref. 1303689), unscrew the microvalve through 4 turns to disengage the thread (see drawing below).

If the plug remains stuck during unscrewing, and the microvalve remains in its housing, disassemble as follows: turn the disassembling tool over (see drawing below); screw the tool onto the microvalve; extract the microvalve with a circular movement.

3.2. Reassembling

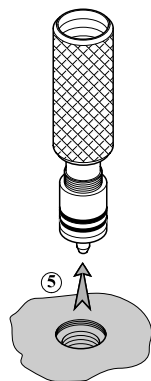

IES00031

Before reassembling the microvalve, check the condition of the bellows and follow the instructions ([see § 4 page 6](#)).

Clean the microvalve housing with solvent. Wipe the housing (check there is no foreign matter). Blow through the control tubes (during disassembly of the microvalve product may enter the control tube and must be blown out).

Coat the body of the new microvalve with vaseline. Fit it with a circular movement (to avoid damaging the seals).

Screw the new microvalve home and lock it using the specific tool (tightening torque 1.5 N.m mini to 2 N.m max).

4. Replacing the microvalve o-rings



WARNING : The outside o-rings must be replaced every time the complete microvalve is disassembled.

4.1. Disassembly

- Remove the o-rings.
- Clean the microvalve with a paint brush.

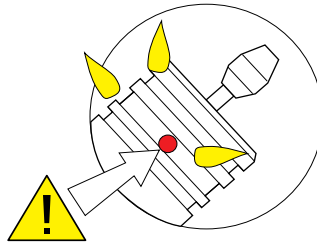

DIES00033



WARNING : Be careful not to let any solvent enter the guide hole.

4.2. Reassembly

Apply a thin coat of vaseline to the body.



WARNING : The o-rings may become deformed if they dry out.

5. Preparing for service

To guarantee efficient sealing between the needle and its housing, the microvalve must be operated 200 times before be putting into service.

6. Problems, troubleshooting.

Symptoms	Causes	Remedies
The microvalve does not open (the operating indicator does not remain in out position at the rear of the microvalve).	The control air does not arrive at the microvalve.	Check the control circuit (control tube folded or disconnected).
	The control pressure is less than 5 bar (73.5 Psi).	Increase the network pressure.
	The needle control rod is stuck. If there is a leak at the gaskets, the paint may dry if the gun is not used for some time preventing the needle rod from moving.	Check if any product has flowed through the venting hole. If so, replace the microvalve.
	The piston seal is damaged. If this seal leaks, pressure cannot build up in the control chamber.	Remove the microvalve. Check that the needle can recede by pushing the end of it with a flat tool. If it does not operate correctly, replace the microvalve.
The microvalve does not close.	The control air circuit remains pressurized.	The control solenoid valve is not operating correctly. The air cannot be drained.
	The return spring is broken.	After disassembling the microvalve, exert a pressure on the end of the needle. If there is no resistance, the spring is worn and the microvalve must be replaced.
	The needle control rod is jammed.	Check that the indicator can move out by pressing on the end of it with a flat tool. If it does not operate correctly, replace the microvalve.
The microvalve no longer acts correctly as a valve.	If the microvalve cannot be closed, the needle does not exert enough pressure on its seat, resulting in product leakage.	See previous symptom.
	The needle is faulty.	Remove the microvalve. Check visually for scratches or faults on the needle. If faults appear, change the microvalve.
	Check for foreign matter on the needle bearing.	Clean as necessary.
	The bellow is broken	Change the microvalve.

7. Spare parts

7.1. Tools

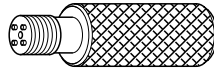

DES00039

Item	Part number	Description	Qty	Unit of sale
1	1303689	Microvalve disassembly tool (4 -pin)	1	1

7.2. 2K-Microvalve with bellow

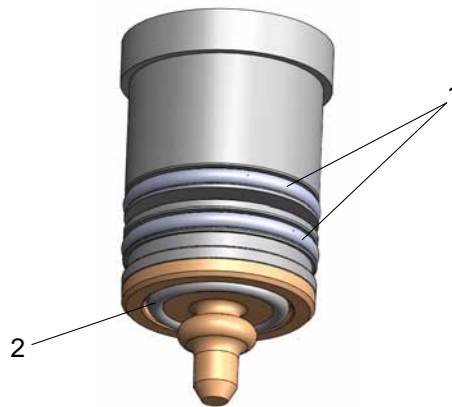

Item	Part number	Description	Qty	Unit of sale	Maintenance level for Spare part (*)
	910010850	2K- microvalve D: 6 orange indicator, chemically inert o-rings		1	1
1	J3STKL239	O ring - chemically inert	2	1	1
2	J3STKL160	O ring - chemically inert	1	1	1

(*)

Level 1: Standard preventive maintenance

Level 2: Corrective maintenance

Level 3: Exceptional maintenance